

Overview:

The Motion Mind comes with a built in ASCII interface that can be used for programming and control. A separate control unit (such as a microcontroller or computer) can implement the ASCII interface. But the primary benefit of the ASCII interface is that common terminal programs may be used to program or control the Motion Mind. The user simply types in ASCII commands and the terminal program displays responses from the Motion Mind. A program most people have access to is Microsoft HyperTerminal. This application note describes how to configure Microsoft HyperTerminal and setup the Motion Mind hardware to implement this simple interface.

Hardware:

You'll need to set the DIP switch settings for ASCII communication and 19.2KBPS. In this application closed-loop serial PID control mode is explored. If you are using a different mode then set DIP switches labeled MOD2, MOD1, and MOD0 accordingly.

DIP Switch Settings

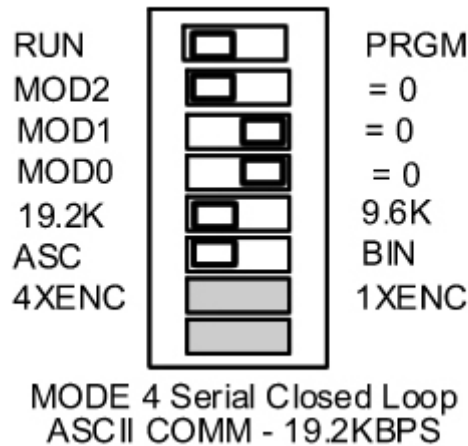

PC Serial Port Connections

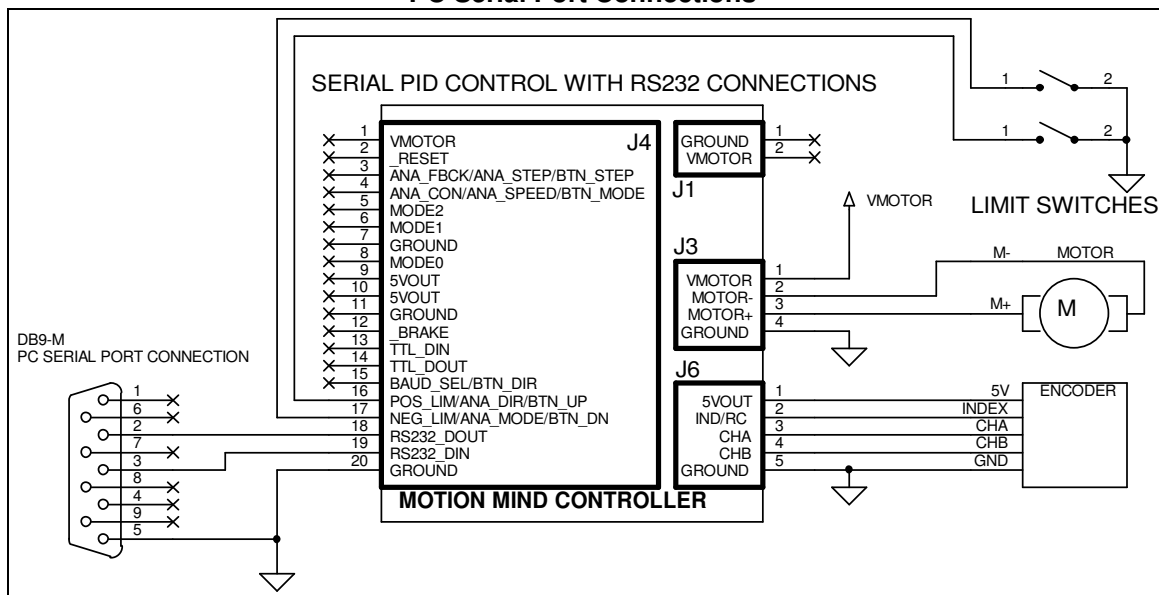

Connections are shown for a DB9 male, which is the connector on the computer serial port. The pin connections are the same for a DB9 female type connector. Using a DB9 female may be worthwhile when you are connecting to a DB9 cable.

Getting Started:

If you have everything connected correctly and power is applied you can now configure Microsoft HyperTerminal to communicate with the Motion Mind. The easiest way to configure Microsoft HyperTerminal to interface with the Motion Mind is to download the configuration file "Motion Mind.ht". Then open this file from within Microsoft HyperTerminal (file/open/ select Motion Mind.ht from the location you downloaded it to). The settings will allow you to communicate with the Motion Mind in ASCII mode.

If you want to go the harder route you can set up the Microsoft HyperTerminal configuration yourself. Follow the steps below to do this (shown in Windows XP).

Step 1: After running Microsoft HyperTerminal select the name and icon for the new connection. Press the "OK" button

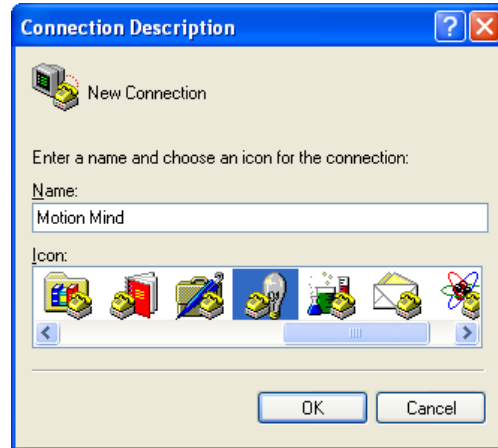

Step 2: In the "Connect To" window select the COMM port you will be using from the "Connect using" pull-down menu. Press the "OK" button



Step 3: The port settings should be 19200BPS, 8 data bits, no parity, 1 stop bit, and no flow control.

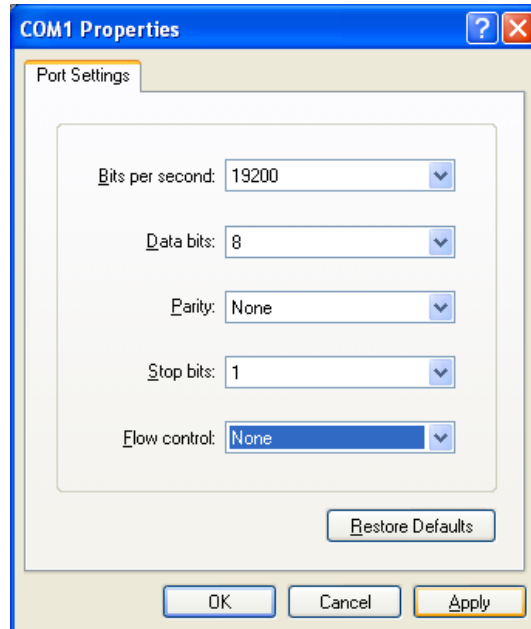

Step 4: From the main program window under the file menu select properties and then the “Settings” tab. Then press the “ASCII Setup” button. Then under “ASCII Sending” select the “Send line ends with line feeds” and “Echo typed characters locally” checkboxes.

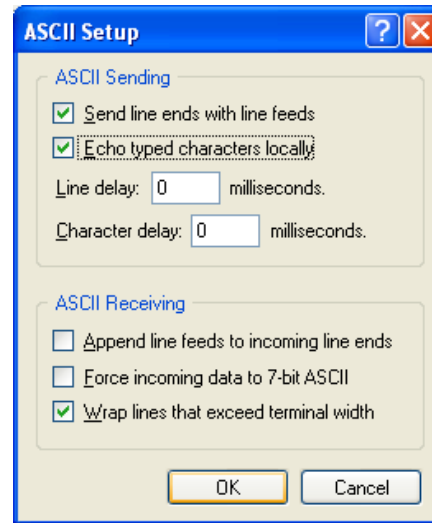
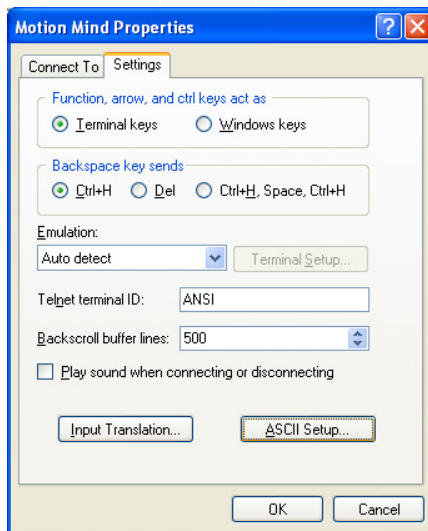

Sending Commands:

Once configured Microsoft HyperTerminal can be used to send commands and receive responses from the Motion Mind. The screen below shows examples of the READ, WRITE, and MOVETO_ABSOLUTE commands. Commands are denoted with red descriptive text (not actually displayed in HyperTerminal) and the responses are denoted with blue descriptive text.

Refer to the Motion Mind datasheet for details on the ASCII command set and communication protocol.

